



VENTO SPI

_Refrigerated shelves. Semi plug-in

Flexible connections for optimum presentation

VENTO SPI are specially designed for use in brine-cooled systems and impress with maximum display area and immense flexibility in design. The VENTO product family can be flexibly expanded and adapted to the conditions in the store.



VISUAL MERCHANDISING

VENTO SPI are a completely flexible and connectable family of refrigerated shelves designed for high product loads. With a wide range of glass door designs and the available low front versions (220 mm), the VENTO SPI are ideally suited for optimum product presentation.



LOW COSTS

The low investment outlay and operating costs speak for themselves. In addition, the VENTO SPI scores with minimum maintenance costs. The integrated and energy-efficient LED head lighting and optional shelf lighting ensure optimum presentation of your goods.



FLEXIBLE SYSTEM

The industrially manufactured refrigeration circuits of the VENTO SPI offer the lowest risk of leakage.



COMPATIBLE WITH THE ACTIVE MONITORING SYSTEM

Our Active Monitoring System (AMS) allows us to detect problems before you notice them. As an essential add-on to all AHT products, the AMS makes it much easier for you to manage and monitor the AHT cooling systems in your stores. Our products are also compatible with other systems.



ENVIRONMENT AND CLIMATE

VENTO SPI operate with a hermetically sealed cooling system and use the ecologically harmless and natural refrigerant propane (R290). This makes them particularly environmentally friendly.

INDIVIDUAL BRANDING

VENTO refrigerated cabinets can be individually adapted to the store design. A wide range of colours allows the best possible integration.



TEMPERATURE RANGES

H1 – Chilled vegetables & fruit	+1°C to +10°C
M2 – Dairy products	-1°C to +7°C
M1 – Dairy products, colder	-1°C to +5°C
M0* – Dairy products, special temp.	-1°C to +4°C
S1* – Meat & fish	-1°C to +2°C

* with GD models only

USPs

FLEXIBLE SYSTEM

VENTO scores with quick installation thanks to simple multiplex connection and the possibility of easy repositioning and system expansion even in existing stores. Piping and a flow control valve for the refrigerated cabinet are already included in the scope of delivery.

HEAT RECOVERY

The waste heat produced by the refrigerated shelves can be utilised for heating the warehouse or other areas of the store. Thanks to the piping supplied on the refrigerated shelves, the waste heat can be conducted to an external pump station and re cooler. That eliminates the need for a separate machine room.



Versions

VENTO SPI GD

VENTO SPI is also available with hinged doors made of glass or plastic. Sliding glass doors are also available. These add-ons make the VENTO more energy efficient, cutting your energy costs.

A large selection of glass door versions for individual design can be found in the accessories catalogue.



VENTO SPI GD ECO

One of the most energy-efficient glass door refrigerated cabinets on the market. VENTO GD ECO operates with just one compressor and thanks to optimised seals is one of the most energy-efficient glass-door refrigerated cabinets on the market – perfect when aiming to minimise your CO₂ footprint.

VENTO SPI GD ROLL-IN

Filling has never been so easy. Floor-length glass or plastic doors allow the VENTO to be filled directly with roll-in trolleys.



VENTO SPI

The semi plug-in multi-deck units are designed for use in brine-cooled systems. A wide range of versions guarantees the best possible integration into your store.

CONFIGURATIONS

Stand-alone



In-line



Block



Island*



_ optionally with end cabinet on both sides

_ specific installation per type on request

*except H8 models



VENTO SPI

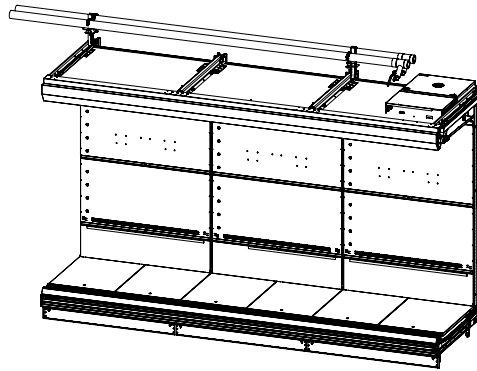
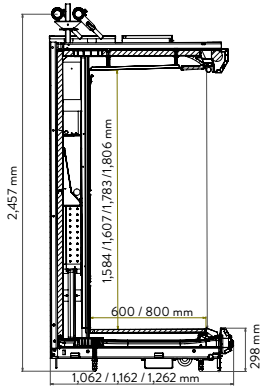

Symbolic image

DIMENSIONS

VENTO SPI		Width	Height	Depth	Shelf depth
EC LS6	mm	1,780	2,200	951	600
LS6	mm	1,780	2,200	951	600
LS6	mm	2,500	2,200	951	600
LS6	mm	3,750	2,200	951	600
EC LS6 ECO*	mm	1,780	2,200	951	600
LS6 ECO*	mm	1,780	2,200	951	600
LS6 ECO*	mm	2,500	2,200	951	600
LS6 ECO*	mm	3,750	2,200	951	600
EC HS6 ECO*	mm	1,780	2,400	951	800
HS6 ECO*	mm	1,780	2,400	951	600
HS6 ECO*	mm	2,500	2,400	951	600
HS6 ECO*	mm	3,750	2,400	951	600
L8	mm	2,500	2,200	1,262	800
L8	mm	3,750	2,200	1,262	800
L8 ECO*	mm	2,500	2,200	1,262	800
L8 ECO*	mm	3,750	2,200	1,262	800
RI L8	mm	2,500	2,400	1,232	800
RI L8	mm	3,750	2,400	1,232	800
LC L8**	mm	2,500	2,350	1,262	800
LC L8**	mm	3,750	2,350	1,262	800
H8	mm	2,500	2,400	1,262	800
H8	mm	3,750	2,400	1,262	800
H8 ECO*	mm	2,500	2,400	1,262	800
H8 ECO*	mm	3,750	2,400	1,262	800
RI H8	mm	2,500	2,400	1,232	800
RI H8	mm	3,750	2,400	1,232	800
LB H8***	mm	2,500	2,350	1,262	800
LB H8***	mm	3,750	2,350	1,262	800

* With glass doors only ** Skirt height 400mm – Electrical components under the refrigerated shelf *** Low front – skirt height 220 mm
 Number of glass swing doors: EC 178/178 – 3 doors, 250 – 4 doors, 375 – 6 doors, irrespective of type
 Further data can be found in the data sheet of the Ecodesign Directive (2009/125/EC).

Subject to technical changes; errors and omissions excepted. Version: 03/2022

AHT
 a member of **DAIKIN** group

AHT Cooling Systems GmbH

Werksgasse 57
 8786 Rottenmann | Austria
 p. +43 3614 24 51-0
 sales@aht.at
 www.aht.at